



## PRODUCT SPECIFICATION

MODEL NO	<b>L6420-1100</b>
INPUT	12VDC
DESCRIPTION	PHOTOCELL & DAYLIGHT HARVESTING SENSOR
CERTIFICATE	UL (E529048)

# 12VDC PHOTOCELL & DAYLIGHT HARVESTING SENSOR

WRITTEN BY	
CHECKED BY (R&D)	
CONFIRMED BY (SALES)	
DATE	2023.02.02

# Features & Benefits

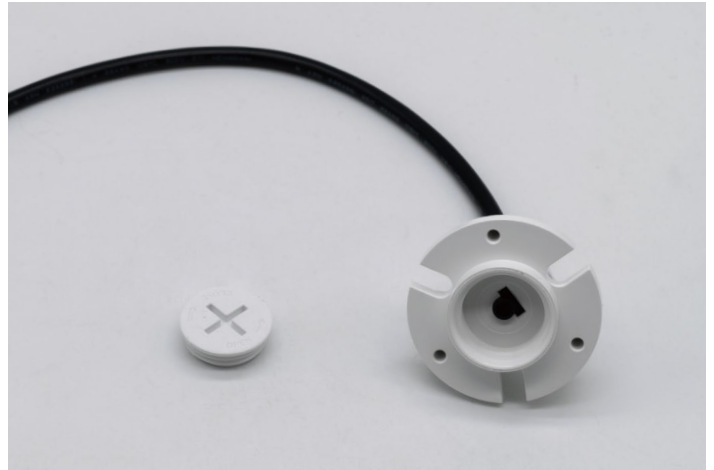

- Photocell & Daylight Harvesting Sensor, no Motion Detection.
- Bi-level dimming, daylight threshold and dusk/dawn function.
- With Audio Jack, suitable for UFO highbay application.
- With UL certificate.

# Demensions Unit:mm

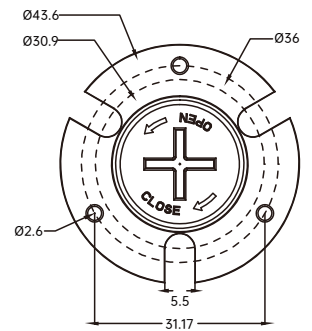
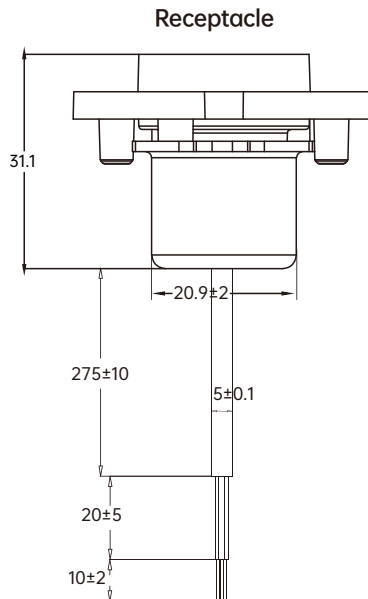
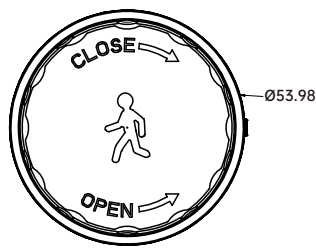
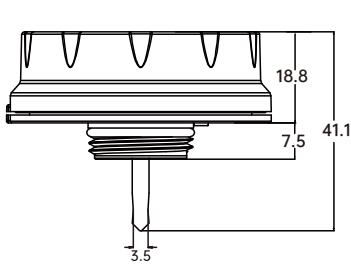

# Parameters

Model NO.		L6420-1100
Daylight Setting	Ambient Brightness Learning	Remote control to learn ambient brightness and daylight harvesting
	Photocell	2Lux/10Lux Light will be off when ambient brightness is 10 times of preset lux level
	Daylight Harvesting	30Lux/50Lux/80Lux/120Lux/200Lux/250Lux/300Lux/350Lux/400Lux
	Control	Standard Partner HD05R, the LCD screen display remote (purchase separately)
	Warranty	5 Years
INPUT	Input Range	12VDC
	Voltage Range	10-15VDC
	Current	≥30mA
	Stand-by Power	<20mA Power Consumption
OUTPUT	Signal	DIM 0-10V
	Connection	12VDC input/ Black&White wire; DIM+/ Purple wire; DIM-/ Pink wire
ENVIRONMENT	Working Temp	-20°C~+60°C
	Storage Temp	-40°C~+80°C Humidity: 85% (non-condensation)
CERTIFICATE & STANDARDS	Certification	UL (E529048)
	Environmental Requirements	In accordance with CE ROHS
	IP Rating	IP65
PACKAGE	Silk-Printing	Lasering
	Packing Description	1pcs/white neutral box
	Qty/ctn(pcs)	200
	Net Weight/pcs (kg)	0.05
	Gross Weight/CTN (kg)	11
	Carton Size (cm)	40*30*25

# Wiring Diagram

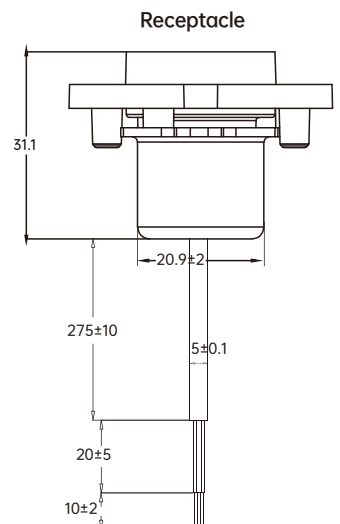
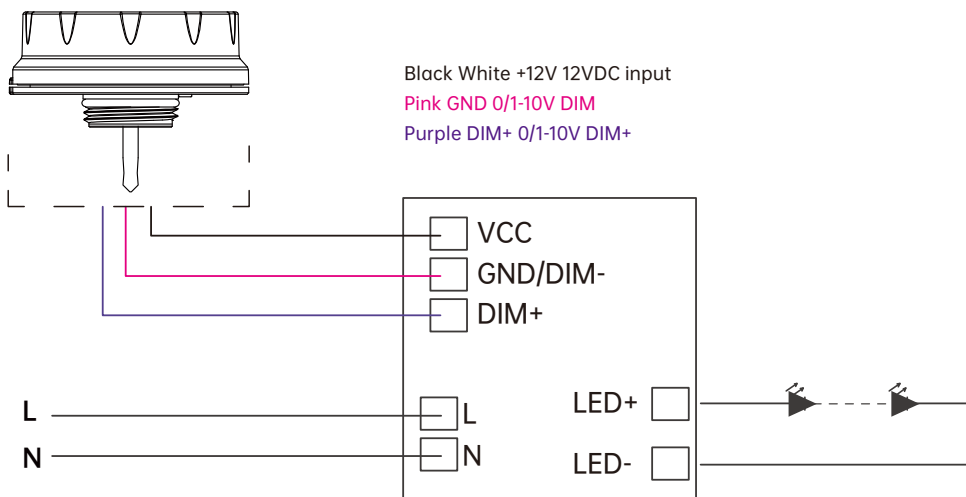

# Daylight Harvesting

## Daylight Harvesting

When ambient brightness is lower than the preset lux level options (30Lux/50Lux/80Lux/120Lux/ 200Lux/250Lux/300Lux/350Lux/400Lux), LED light will be darker when ambient is getting brighter, and brighter when darker; when ambient brightness is brighter than preset lux level, light off.

When daylight threshold set as 30Lux/50Lux/80Lux/120Lux/200Lux/250Lux/300Lux/350Lux/400Lux, it performs daylight harvesting function.

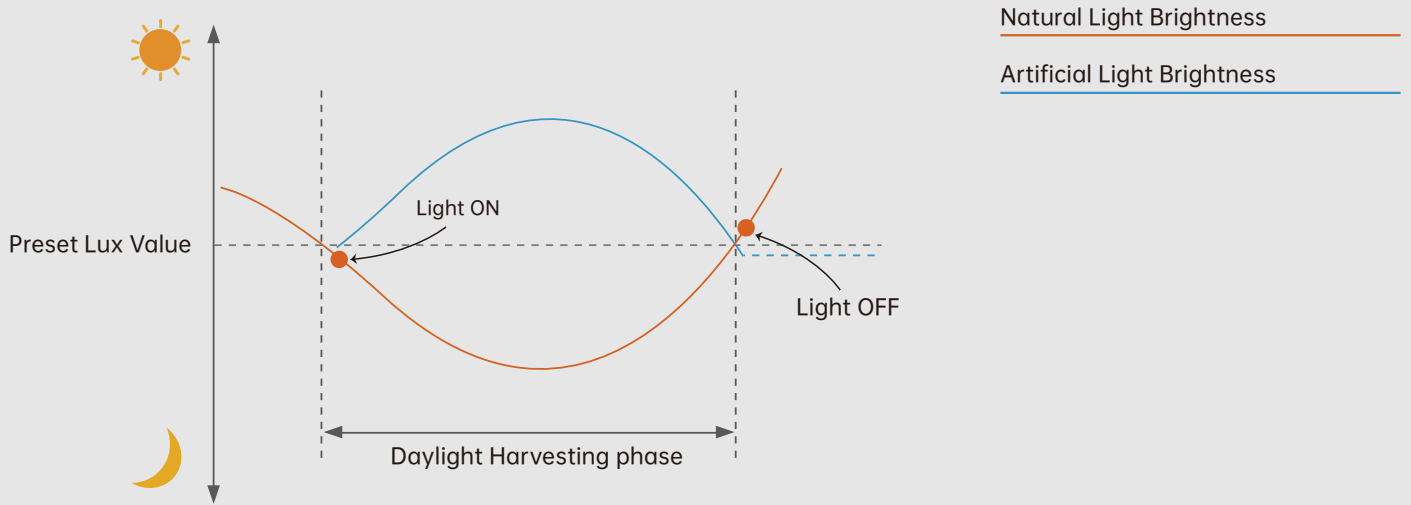

# Application of Daylight Harvesting

Daylight threshold preset as 30Lux/50Lux/80Lux/120Lux/200Lux/250Lux/300Lux/350Lux/400Lux

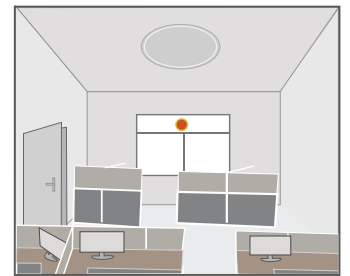
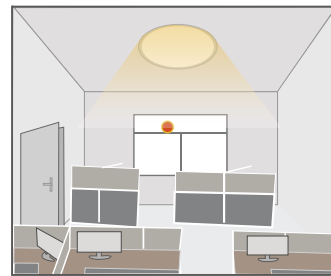
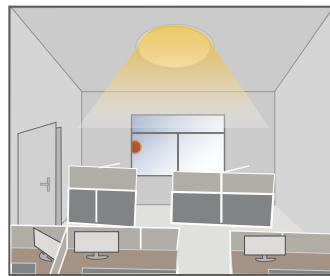
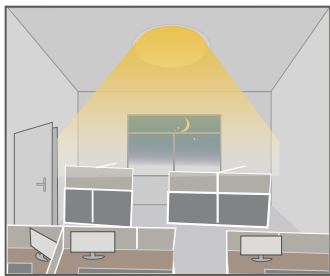

When ambient brightness is lower than preset lux level, sensor will turn on light automatically and keep dimming according to the change of the ambient brightness; when outside is getting darker, the inside will be brighter, and brighter darker.

Light OFF when ambient brightness becomes higher than the preset lux level.

# Photocell

The sensor performs photocell function when preset lux level is only 2Lux/10Lux.

1. Light will automatically ON when ambient brightness is lower than preset level. (Scene 1)
2. Light will automatically OFF when ambient brightness is 10 times higher than preset level. (Scene 2)

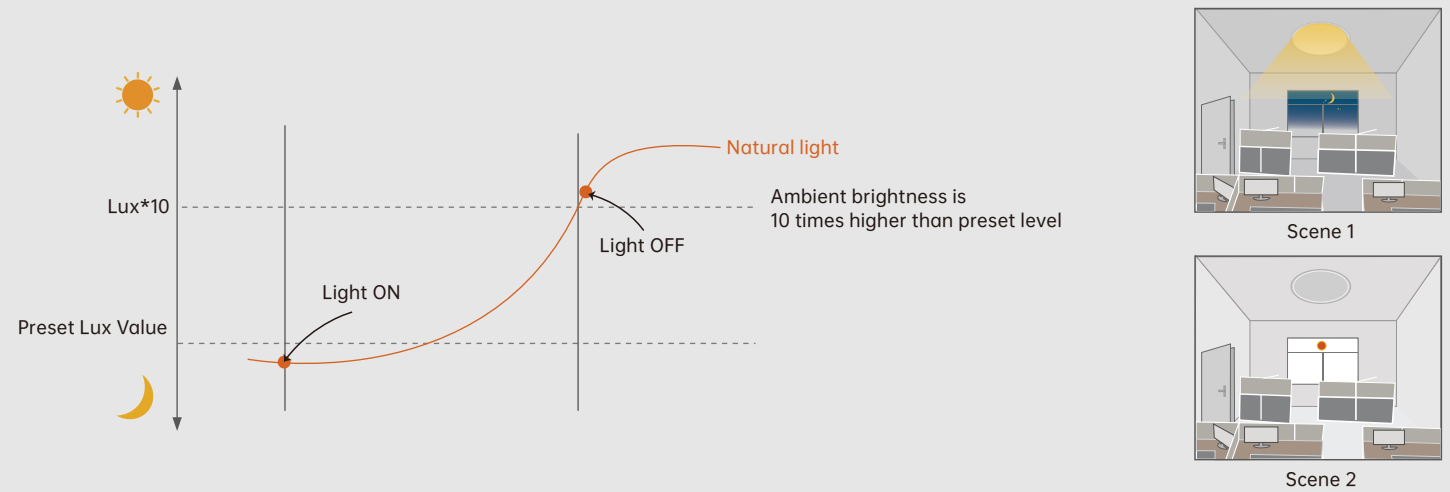

# Ambient Brightness Learning

Instead of giving a specific lux level, this function enables current ambient brightness to be learnt and set as a standard lux level; When ambient brightness is getting darker, the artificial light will be brighter; and brighter darker; When ambient brightness exceeds the standard level, light will turn off.

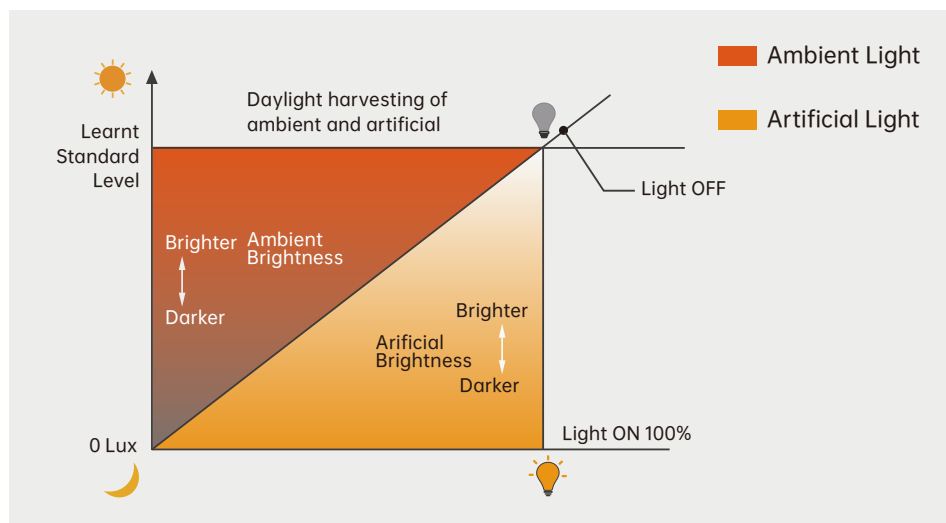

## How To Learn Ambient Brightness

1. Light ON, use HD05R remote;
2. Press " Scene " button;
3. Then press MW/PIR button twice till you see the MW icon and PIR icon on the screen display start flashing, then the light will keep OFF for about 3S and turn ON again, that means learning completed.



## Attention

1. The sensor should be installed by qualified electrician and ensure power is OFF before installation.
2. Please read the instruction carefully before using the product and keep it well for other users to read any time.
3. We reserve the right to modify any incorrect text, image and technical parameters.
4. Any unauthorized modification is forbidden. Otherwise all guarantees will be immediately invalid.
5. Product could be optimized without prior notice.

## APPLICATION NOTES

1. Suitable for indoor application, half/completely outdoor environment conditions might be captured as moving signals to trigger the sensor.
2. Suitable for ceiling mount installation, adjust sensitivity properly if it's installed on side-wall because it gets more sensitive.
3. Adjust sensitivity properly when the sensor is applied in small/narrow/metal-built/with metal spaces.
4. Microwave sensor can't be placed under/inside metal shell; Microwave module must directly face the detection area with edge lower than light fixture.
5. Keep the sensor away from vibration equipments, air-conditioning outlets, smoke extractors alike conditions to avoid unwanted trigger.
6. Keep the sensor module away from AC input and DC output to avoid high/low frequency signal interference.
7. At least 2m/6.5ft distance between microwave sensors; 1.5m/4.9ft between the sensor and other wireless devices such as routers to avoid possible radio interference.
8. Daylight testing delivered in bright day without shadow or specially designed lampshade or lens.
9. Dimming performance differs when connected to different drivers; If the driver can't completely turn OFF, sensor can't either.
10. Input power voltage must be stable with float less than 10%.
11. The first time powered ON sensor, light will be ON 100% for about 10S then dims to standby level or OFF.
12. Distance detection is delivered by testing person about 165cm in open area as reference, the result differs by size and speed of moving objects, mounting height and real-life situation.